

ZEROTRONIC SENSORS AND DYNAM SOFTWARE / INCLINATION MEASURING SYSTEM

INDEX: "D" / 30.4.1997 (MASSBILD: LÄNGEN NEU, SEITEN 1+2)

1. SPECIFICATIONS SENSOR ZEROTRONIC

1.1. FEATURES

- RS485 Bus-Interface
- Automatic baudrate detection 4'800 .. 115'200 baud
- 32 Sensors on the same RS485 bus
- Auxilliary digital encoder input
- Optional **analog** output

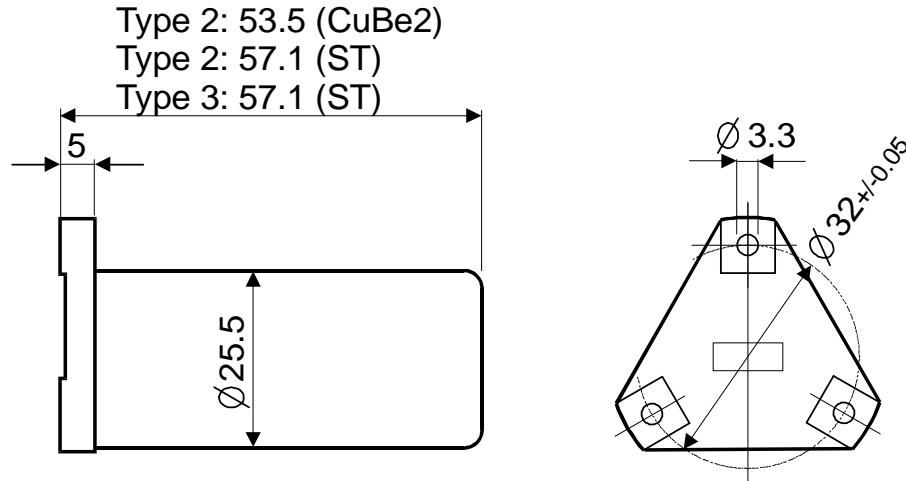

Pin-assignment:

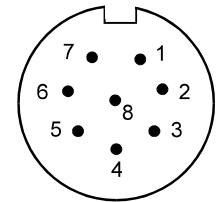

1.2. DESCRIPTION PIN-ASSIGNMENT

Pin Number	Pin Name	Pin Type	Pin Function
1	ENA	Input	Position Encoder A (Type 2 only)
2	VSS	Input/Output	Ground
3	VDD	Input	Power
4	RTA	Input/Output	RS485-Line A
5	RTB	Input/Output	RS485-Line B
6	PWM	Output	PWM-Signal (Type 3 only) (0.1 x (VDD-VSS) ⇔ - Fullscale) (0.9 x (VDD-VSS) ⇔ + Fullscale)
7	RTS	Output O.C.	Request to send
8	ENB	Input	Position Encoder B (Type 2 only)

1.3. SENSOR SPECIFICATIONS

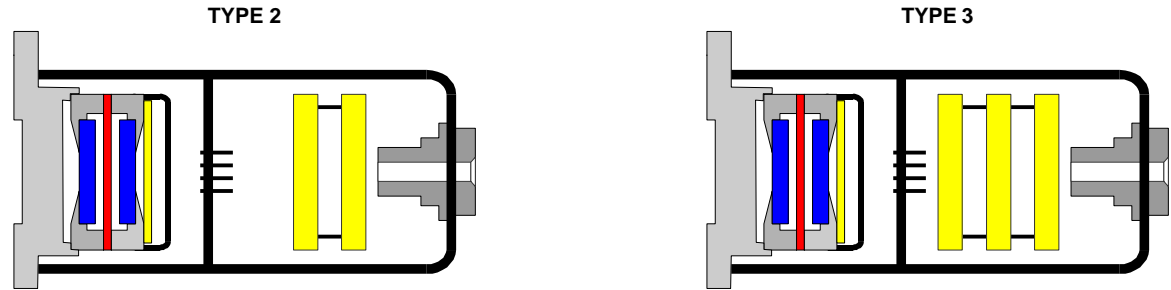
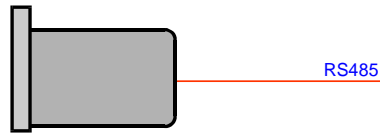

SPECIFICATION	ZERO 1	ZERO 10	ZERO 30	ZERO 60	ZEROMATIC 50
Fullscale	+/- 1°	+/- 10°	+/- 30°	+/- 60°	+/- 0.5°
Limits of error within 24 hours (TA = 20°C)	0.017% F.S. + 0.07% R.O.	0.0042% F.S. + 0.02% R.O.	0.0046% F.S. + 0.01% R.O.	0.0037% F.S. + 0.01% R.O.	0.015% F.S. + 0.04% R.O.
Limits of error within 6 months (TA = 20°C)	0.14% F.S. + 0.25% R.O.	0.055% F.S. + 0.15% R.O.	0.037% F.S. + 0.1% R.O.	0.028% F.S. + 0.06% R.O.	0.15% F.S. + 0.10% R.O.
1) Temperatur error / °C (-40°C <= TA <= 85°C)	0.04% F.S. + 0.2% R.O.	0.008% F.S. + 0.03% R.O.	0.005% F.S. + 0.02% R.O.	0.004% F.S. + 0.01% R.O.	0.04% F.S. + 0.2% R.O.
Resolution (TA = 20°C) (Sampling-Time: 0.1 sec) w/o Filter with Filter	+/- 0.0358 % F.S. +/- 0.0128 % F.S.	+/- 0.00888 % F.S. +/- 0.00315 % F.S.	+/- 0.0143 % F.S. +/- 0.00454 % F.S.	+/- 0.0131 % F.S. +/- 0.00430 % F.S.	+/- 0.00859 % F.S. +/- 0.00286 % F.S.
(Sampling -Time: 1.0 sec) w/o Filter with Filter	+/- 0.0128 % F.S. +/- 0.00429 % F.S.	+/- 0.00315 % F.S. +/- 0.00100 % F.S.	+/- 0.00454 % F.S. +/- 0.00124 % F.S.	+/- 0.00430 % F.S. +/- 0.00122 % F.S.	+/- 0.00286 % F.S. +/- 0.00100 % F.S.
(Sampling -Time: 10.0 sec) w/o Filter with Filter	+/- 0.00429 % F.S. +/- 0.00222 % F.S.	+/- 0.00100 % F.S. +/- 0.000573 % F.S.	+/- 0.00124 % F.S. +/- 0.000668 % F.S.	+/- 0.00122 % F.S. +/- 0.000692 % F.S.	+/- 0.00100 % F.S. +/- 0.000458 % F.S.
Repetition	Repetition is included in „Resolution“, see above				
Differential Linearity (within 0.1% F.S.)	Differential Linearity is included in „Resolution“, see above				

1) Temperature error with compensation will be reduced by factor 5 to 10!

<p>Remarks: F.S. => fullscale R.O. => readout w/o Filter => raw values with Filter => floating average over 10 values Resolution means smallest stable value available (noise) All the specifications listed are given only as typical values</p>	<p>The sensor as such is acting like an <u>integrating A/D converter</u>. This means that during the pre-set sampling time (which is max. 2 seconds) all the various internally collected values (angles or frequencies) will be integrated to one single signal.</p>
---	---

1.4. ABSOLUTMAXIMUM RATINGS †

Supply Voltage VDD with respect to VSS	0V to + 7V
Input Voltage ENA,ENB and RTS with respect to Vss	- 0.5V to VDD + 0.5V
Input Voltage RTA and RTB with respect to VSS	- 14V to + 14V
Ambient temperature under bias	- 55°C to + 95°C
Storage temperature	- 55°C to + 95°C

† **Notice:** Stresses above those listed under „Maximum Ratings“ may cause permanent damage to the device!

1.5. DC CHARACTERISTICS

Operation Conditions: $4.5V \leq VDD \leq 5.5V$, $-40^{\circ}C \leq TA \leq 85^{\circ}C$

Characteristic	Symbol	Min	Typ	Max	Unit	Conditions
Supply voltages and currents						
Supply Voltage	VDD	4.5	5.0	5.5	V	
Supply Current	IDD		8.5	20	mA	I _{OD} = 0
Encoder inputs ENA & ENB						
Input Low Voltage	V _{IL}	0.8			V	
Input High Voltage	V _{IH}			2.4	V	
Input Current	I _{IN}	- 0.5		0.5	mA	$0V \leq V_{IN} \leq V_{DD}$
RTS output (OpenCollector)						
Output Low Voltage	V _{OL}			0.4	V	I _{OL} = - 20 mA
Output High Voltage	V _{OH}			VDD + 0.5	V	
RS485 parameter RTA & RTB						
Common Mode Input Voltage	V _{CM}	- 7		12	V	
Receiver Input Hysteresis	V _{TH}		70		mV	V _{CM} = 0V
Receiver Input Resistance	R _{IN}	12			kΩ	$- 7V \leq V_{CM} \leq + 12V$
Differential Driver Output Voltage	V _{OD}	1.5		VDD	V	R = 27Ω
Driver Output Current	I _{OD}	55			mA	

1.6. RS485 INTERFACE

Parameter	Value
Databit	7
Stopbit	2
Parity	None
Baurate	4800 to 115200 Baud

1.7. RS485 MESSAGES HOST <<<--->>> ZEROTRONIC

1..6	7	8	9	10	11	12	13	14	15	16	17	18	19	20	21
----- ASCII-Characters '0'...'9' und 'A' bis 'F' ⇔ Nibble Values 0...15															<CR>
HEADER		RS485 Address		Sub Adress	Opcode	Data						Checksum		Trailer	

	3210	3210	3210	3210	3210	3210	3210	3210	3210	3210	3210	3210	3210	3210	
	dddd	dddd	dddd	dddd	dddd	dddd	dddd	Dddd	dddd	dddd	dddd	dddd	cccc	cccc	d=Data c[7...0] = Checksum of data nibbles
	aaaa	aaaa	ssss												a[7...0] = RS485-Address s=[3...0] = Sub-Address
ReadID	HOST to ZEROTRONIC			0001	0000	0000	0000	0000	0000	0000	0000	0000	0000	0000	
	ZEROTRONIC to HOST			0000	####	####	####	####	####	####	####	####	####	####	i[11..0] = Type (2 = Type2 3 = Type3)
WriteGateTime	HOST to ZEROTRONIC			1010	0000	0000	0011	1010	0000	tttt	tttt	tttt			t[11..0] = Time [ms]
	ZEROTRONIC to HOST			0000	####	####	####	####	####	####	####	####	####	####	
Write Synch	HOST to ZEROTRONIC			1001	0000	0000	0000	0000	0000	0000	0000	0000			
	ZEROTRONIC to HOST			0000	####	####	####	####	####	####	####	####	####	####	
WriteEEPROM	HOST to ZEROTRONIC			1100	0000	0000	0101	0aaa	aaaa	aaaa	dddd	dddd			a[10..0] = EEPROM-Address d[7..0] = EEPROM-Data
	ZEROTRONIC to HOST			0000	####	####	####	####	####	####	####	####	####	####	
ReadEEPROM	HOST to ZEROTRONIC			0010	0000	0000	0101	0aaa	aaaa	aaaa	0000	0000			a[10..0] = EEPROM-Address
	ZEROTRONIC to HOST			0000	####	####	####	####	####	####	####	####	dddd	dddd	d[7..0] = EEPROM-Data
ReadCountS0	HOST to ZEROTRONIC			0101	0000	0000	0000	0000	0000	0000	0000	0000			
	ZEROTRONIC to HOST			0000	ssss	cccc	cccc	Cccc	cccc	cccc	cccc	cccc	cccc	cccc	s[3..0] = Sequence c[27..0] = CountS0
ReadCountS1	HOST to ZEROTRONIC			0110	0000	0000	0000	0000	0000	0000	0000	0000			
	ZEROTRONIC to HOST			0000	ssss	cccc	cccc	Cccc	cccc	cccc	cccc	cccc	cccc	cccc	s[3..0] = Sequence c[27..0] = CountS1
ReadCountT	HOST to ZEROTRONIC			1000	0000	0000	0000	0000	0000	0000	0000	0000			
	ZEROTRONIC to HOST			0000	aaaa	aaaa	aaaa	Aaaa	bbbb	bbbb	bbbb	bbbb			a[15..0] = CountT1 b[15..0] = CountT0
ReadPosition	HOST to ZEROTRONIC			0111	0000	0000	0000	0000	0000	0000	0000	0000			
	ZEROTRONIC to HOST			0000	ssss	pppp	pppp	Pppp	pppp	pppp	pppp	pppp	pppp	pppp	s[3..0] = Sequence p[27..0] = Position
ReadActualPos	HOST to ZEROTRONIC			0100	0000	0000	0000	0000	0000	0000	0000	0000			
	ZEROTRONIC to HOST			0000	pppp	pppp	pppp	Pppp	pppp	pppp	pppp	pppp	pppp	pppp	p[31..0] = Position
WritePort	HOST to ZEROTRONIC			1011	0000	0000	0000	0000	0000	0000	0000	000d	dddd		d[4..0] = PortData
	ZEROTRONIC to HOST			0000	####	####	####	####	####	####	####	####	####	####	
ReadPort	HOST to ZEROTRONIC			0011	0000	0000	0000	0000	0000	0000	0000	0000	0000		
	ZEROTRONIC to HOST			0000	####	####	####	####	####	####	####	####	####d	dddd	d[4..0] = PortData
ReadAngle(*)	HOST to ZEROTRONIC			1101	0000	0000	0000	0000	0000	0000	0000	0000	0000		
	ZEROTRONIC to HOST			0000	ssss	iiii	Ffff	ffff	ffff	ffff	ffff	ffff	ffff	ffff	s[3..0] = Sequence i[3..0].f[23..0] = Angle [radian]

Remarks: (*) = Type3 commands (#) = undefined / don't care

1.8. SPECIFICATIONS TRANSCEIVER T/C

1.8.1. FEATURES

- Automatic baudrate detection 4'800 .. 57'600 baud
- Port 1 (RS485) and Port 2(RS485): RS485 Interface for up to 32 Sensors
- Port 3 (PC/RS232): RS232 Bus-Interface
- Port 4 (Sensor A) and Port 5 (Sensor B): RS485 Interface for up to 5 Sensors each
- Ports 3 / 4 / 5 are electrically isolated Interfaces

Distances:

- Port 1 and Port 2 to Sensors: max. 15 Meters
- Port 1 and Port 2 to next T/C: max. 1200 Meters
- Port 4 and Port 5 to Sensors: max. 15 Meters
- Port 3 to PC: max. 2.5 Meters

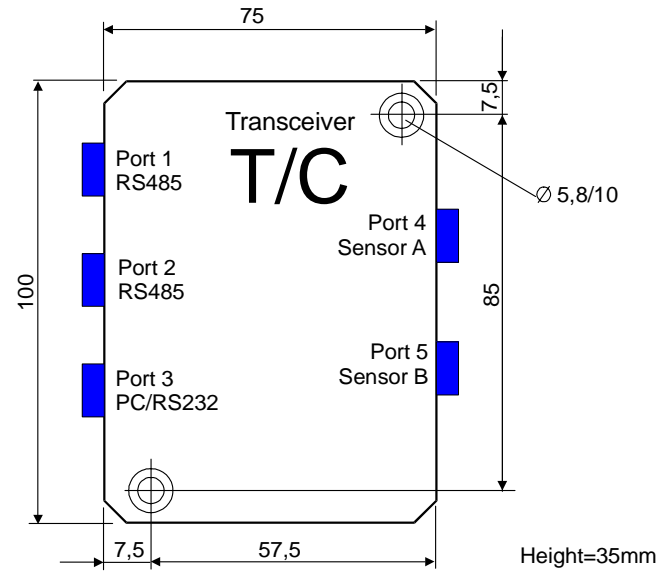

Pin assignment::

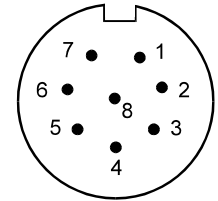

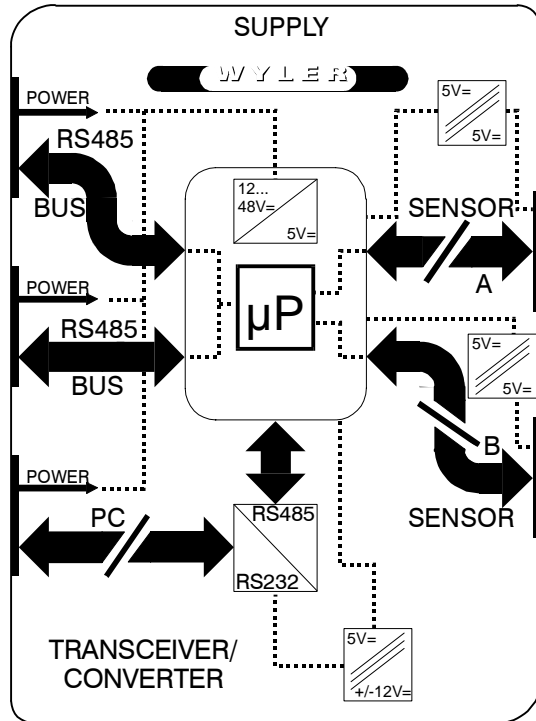

Colour of LED	Light characteristic	Function
Yellow	Continuous	Ready, powered, no communication
Yellow	Intermittent 2 sec	Hardware error (internal or cable)
Green	Continuous, to short intervals	Communication successful
red	Continuous, to short intervals	Contact with PC, no answer on BUS

Remarks:

LED of all TC's are not directly connected to RS232 line (PC), change status at a speed not noticeable. In this case the LED looks yellow

Remarks: /// means: galvanic isolation
All 5 connectors are Binder Serie 712, 8 pol female

1.8.2. DESCRIPTION PIN-ASSIGNMENT
1.8.2.1. PIN-ASSIGNMENT PORT 1 AND PORT 2

Pin Number	Pin Name	Pin Type	Pin Function
1	VPP	Input/Output	Unregulated Power
2	VSS	Input/Output	Ground
3	VDD	Input/Output	Power
4	RTA	Input/Output	RS485-Line A
5	RTB	Input/Output	RS485-Line B
6	-	-	-
7	-	-	-
8	-	-	-

1.8.2.2. PIN-ASSIGNMENT PORT 3

Pin Number	Pin Name	Pin Type	Pin Function
1	VPP	Input/Output	Unregulated Power
2	VSS	Input/Output	Ground
3	TD	Output	RS232-Line TD
4	-	-	-
5	RD	Input	RS232-Line RD
6	-	-	-
7	Ground	Input/Output	RS232-Line Ground
8	-	-	-

1.8.2.3. PIN-ASSIGNMENT PORT 4 AND PORT 5

Pin Number	Pin Name	Pin Type	Pin Function
1	-	-	-
2	VSS	Input/Output	Ground
3	VDD	Output	Power
4	RTA	Input/Output	RS485-Line A
5	RTB	Input/Output	RS485-Line B
6	-	-	-
7	RTS	Input	Request to send
8	-	-	-

1.9. ABSOLUTMAXIMUM RATINGS †

Unregulated Supply Voltage V _{PP} with respect to V _{SS}	0V to + 60V
Supply Voltage V _{DD} with respect to V _{SS}	0V to + 7V
Input Voltage ENA, ENB and RTS with respect to V _{SS}	- 0.5V to V_{DD} + 0.5V
Input Voltage RTA and RTB with respect to V _{SS}	- 14V to + 14V
Ambient temperature under bias	- 55°C to + 95°C
Storage temperature	- 55°C to + 95°C

† **Notice:** Stresses above those listed under „Maximum Ratings“ may cause permanent damage to the device!

1.10. DC CHARACTERISTICS

Operation Conditions: 4.5V ≤ V_{DD} ≤ 5.5V, -40°C ≤ T_A ≤ 85°C

Characteristic	Symbol	Min	Typ	Max	Unit	Conditions	
Supply voltages and currents							
Unregulated Supply Voltage	V _{PP}	10.0		56.0	V	I _{DD} = 0	
Regulated Supply Voltage	V _{DD}	4.5		5.5	V	V _{PP} = 0.0 V I _{PP} = 0	
Supply Current	I _{PP}		160.0		MA	V _{PP} = 10.0V I _{DD} = 0	
			60.0		MA		V _{PP} = 24.0V I _{DD} = 0
			100.0		MA		V _{PP} = 0.0 V I _{PP} = 0
RTS input							
Input Low Voltage	V _{IL}	2.4		0.8	V	V _{IN} = 0.0 V	
Input High Voltage	V _{IH}			V			
Input Current	I _{IN}			6.0	MA		
RS485 parameter RTA & RTB							
Common Mode Input Voltage	V _{CM}	- 7		12	V		
Receiver Input Hysteresis	V _{TH}		70		mV	V _{CM} = 0V	
Receiver Input Resistance	R _{IN}	12			kΩ	- 7V ≤ V _{CM} ≤ + 12V	
Differential Driver Output Voltage	V _{OD}	1.5		V _{DD}	V	R = 27Ω	
Driver Output Current	I _{OD}	55			mA		

1.11. RS232 INTERFACE

Parameter	Value
Databit	7
Stopbit	2
Parity	None
Baurate	4800 to 57600 Baud

1.12. RS232 MESSAGES HOST <<<--->>> TRANSCEIVER (T/C)

1 .. 6	7	8	9	10	11	12	13	14	15	16	17	18	19	20	21	22 .. 49	
ASCII-Characters '0'...'9' und 'A' bis 'F' ↔ Nibble Values 0...15															<CR>	Padding Character (+)	
HEADER	RS485 Address		Sub Address	Opcode	Data (-)								Checksum		Trailer		
	3210	3210	3210	3210	3210	3210	3210	3210	3210	3210	3210	3210	3210	3210			
	dddd	Dddd	dddd	dddd	dddd	dddd	dddd	dddd	dddd	dddd	dddd	dddd	cccc	cccc	d=Data c[7...0] = Checksum of data nibbles		
	aaaa	Aaaa	ssss													a[7...0] = RS485-Address s=[3...0] = Sub-Address	
ReadID	HOST to T/C and ZEROTRONIC ZEROTRONIC to Transceiver			0001	0000	0000	0000	0000	0000	0000	0000	0000					d=Data c[7...0] = Checksum of data nibbles
WriteGateTime	HOST to T/C and ZEROTRONIC ZEROTRONIC to Transceiver			1010	0000	0000	0011	1010	0000	tttt	tttt	tttt					i[11..0] = Type (2 = Type2 3 = Type3) t[11..0] = Time [ms]
Write Synch	HOST to T/C and ZEROTRONIC ZEROTRONIC to Transceiver			1001	0000	0000	0000	0000	0000	0000	0000	0000					
WriteEEPROM	HOST to T/C and ZEROTRONIC ZEROTRONIC to Transceiver			1100	0000	0000	0101	0aaa	aaaa	aaaa	dddd	dddd					a[10..0] = EEPROM-Address d[7..0] = EEPROM-Data
ReadEEPROM	HOST to T/C and ZEROTRONIC ZEROTRONIC to Transceiver			0010	0000	0000	0101	0aaa	aaaa	aaaa	0000	0000					a[10..0] = EEPROM-Address d[7..0] = EEPROM-Data
ReadCountS0	HOST to T/C and ZEROTRONIC ZEROTRONIC to Transceiver			0101	0000	0000	0000	0000	0000	0000	0000	0000					s[3..0] = Sequence c[27..0] = CountS0
ReadCountS1	HOST to T/C and ZEROTRONIC ZEROTRONIC to Transceiver			0110	0000	0000	0000	0000	0000	0000	0000	0000					s[3..0] = Sequence c[27..0] = CountS1
ReadCountT	HOST to T/C and ZEROTRONIC ZEROTRONIC to Transceiver			1000	0000	0000	0000	0000	0000	0000	0000	0000					a[15..0] = CountT1 b[15..0] = CountT0
ReadPosition	HOST to T/C and ZEROTRONIC ZEROTRONIC to Transceiver			0111	0000	0000	0000	0000	0000	0000	0000	0000					s[3..0] = Sequence p[27..0] = Position
ReadActualPos	HOST to T/C and ZEROTRONIC ZEROTRONIC to Transceiver			0100	0000	0000	0000	0000	0000	0000	0000	0000					p[31..0] = Position
WritePort	HOST to T/C and ZEROTRONIC ZEROTRONIC to Transceiver			1011	0000	0000	0000	0000	0000	0000	0000	000d	dddd				d[4..0] = PortData
ReadPort	HOST to T/C and ZEROTRONIC ZEROTRONIC to Transceiver			0011	0000	0000	0000	0000	0000	0000	0000	0000	0000	0000	0000	0000	d[4..0] = PortData
ReadAngle(*)	HOST to T/C and ZEROTRONIC ZEROTRONIC to Transceiver			1101	0000	0000	0000	0000	0000	0000	0000	0000	0000	0000	0000	0000	s[3..0] = Sequence i[3..0].f[23..0] = Angle [radian]

Remarks: (*) = Type3 commands (#) = undefined / don't care

Remarks:
(+) (Description Padding):

The padding CHAR signals the message-sequence-number (0,1,2,3,0,1,2.....)

Padding CHAR	0x7C = Sequence Number	'XXXXXX00'
	0x78	'XXXXXX01'
	0x70	'XXXXXX10'
	0x60	'XXXXXX11'
	0x40	'00000000'

(-) = The data

The data[31:0] is sent to the HOST along with a message-sequence-number[7:0] and longitude-parity-information[4:0]. If one of the nine bytes gets lost due to HOST receiver overrun error the data and message-sequence number can be retrieved form the remaining eight bytes of the message.

CHAR	Bit 6	Bit 5	Bit 4	Bit 3	Bit 2	Bit 1	Bit 0
1	0	0	Data[04]	Data[03]	Data[02]	Data[01]	Data[00]
2	0	1	Data[09]	Data[08]	Data[07]	Data[06]	Data[05]
3	1	0	Data[14]	Data[13]	Data[12]	Data[11]	Data[10]
4	0	1	Data[19]	Data[18]	Data[17]	Data[16]	Data[15]
5	1	0	Data[24]	Data[23]	Data[22]	Data[21]	Data[20]
6	0	1	Data[29]	Data[28]	Data[27]	Data[26]	Data[25]
7	1	0	SEQ.N[2]	SEQ.N[1]	SEQ.N[0]	Data[31]	Data[30]
8	0	1	SEQ.N[7]	SEQ.N[6]	SEQ.N[5]	SEQ.N[4]	SEQ.N[3]
9	1	1	L.P. [4]	L.P. [3]	L.P. [2]	L.P. [1]	L.P. [0]

2. CONFIGURATION WITH WYLER NETWORK ... RS485

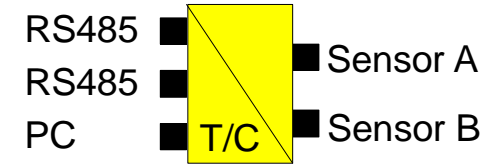
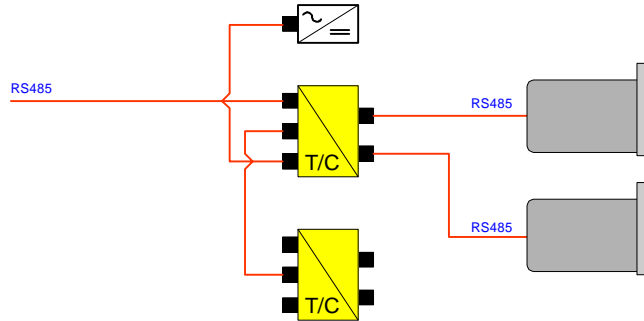

2.1. SAMPLE ANGLE READOUT FLOWCHART (RS485)

Type2

Initialization	(RS485-Address = 5, Sub-Address = 1, Sampling-Time = 1.0 s)	HOST ⇒ ZEROTRONIC	ZEROTRONIC ⇒ HOST
Read Calibration Data	Calibration-Data.Byte[62] = ReadEEPROM(5.1, 62)	~~~~~051200503E001E↓	~~~~~0510.....dd...↓
	Calibration-Data.Byte[63] = ReadEEPROM(5.1, 63)	~~~~~051200503F001F↓	~~~~~0510.....dd...↓
	...	~~~~~0512005....	~~~~~0510.....dd...↓
Write Sampling-Time	WriteGateTime(5.1, 500)	~~~~~051A003A01F431↓	~~~~~0510.....↓
Measurement Loop			
Read Counts	CountS0 = ReadCountS0(5.1)	~~~~~0515000000000B↓	~~~~~0510scccccc...↓
	CountS1 = ReadCountS1(5.1)	~~~~~0516000000000C↓	~~~~~0510scccccc...↓
Calculate Angle(*)	Angle = f(CountS0, CountS1, Calibration-Data)		

(*) = Program code written in 'C' may be provided by WYLER AG

Type3

Initialization	(RS485-Address = 5, Sub-Address = 1, Sampling-Time = 1.0 s)	HOST ⇒ ZEROTRONIC	ZEROTRONIC ⇒ HOST
Write Sampling-Time	WriteGateTime(5.1, 500)	~~~~~051A003A01F431↓	~~~~~0510.....↓
Measurement Loop			
Read Angle	Angle = ReadAngle(5.1)	~~~~~051D0000000013↓	~~~~~0510sifffff...↓

3. CONFIGURATION WITH WYLER NETWORK ... RS232

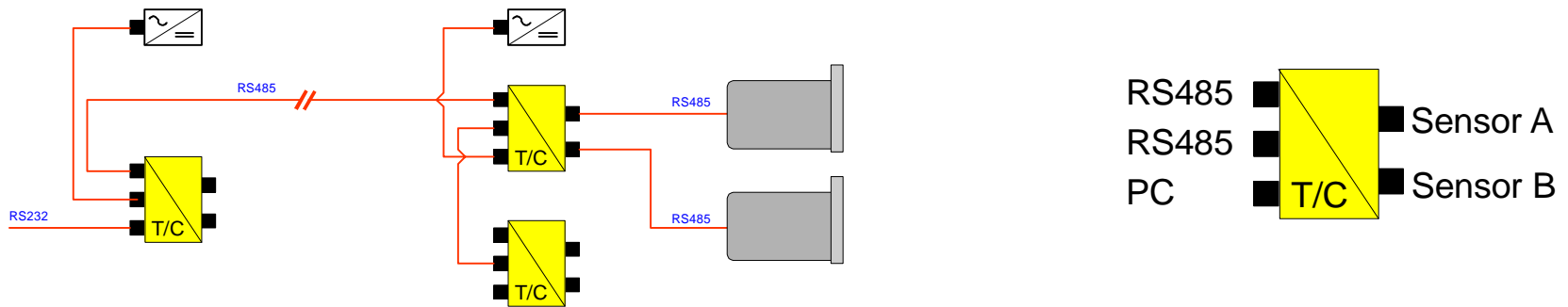

3.1. SAMPLE ANGLE READOUT FLOWCHART (RS232)

Type2

Initialization	(RS485-Address = 5, Sub-Address = 1, Sampling-Time = 1.0 s)	HOST ⇒ T/C ⇒ ZEROTRONIC	T/C ⇒ HOST
Read Calibration Data	Calibration-Data.Byte[62] = ReadEEPROM(5.1, 62)	~~~~~051200503E001E↓.....
	Calibration-Data.Byte[63] = ReadEEPROM(5.1, 63)	~~~~~051200503F001F↓.....
	...	~~~~~0512005....
Write Sampling-Time	WriteGateTime(5.1, 500)	~~~~~051A003A01F431↓.....
Measurement Loop			
Read Counts	CountS0 = ReadCountS0(5.1)	~~~~~0515000000000B↓.....
	CountS1 = ReadCountS1(5.1)	~~~~~0516000000000C↓.....
Calculate Angle(*)	Angle = f(CountS0, CountS1, Calibration-Data)		

(*) = Program code written in 'C' may be provided by WYLER AG

Type3

Initialization	(RS485-Address = 5, Sub-Address = 1, Sampling-Time = 1.0 s)	HOST ⇒ T/C ⇒ ZEROTRONIC	T/C ⇒ HOST
Write Sampling-Time	WriteGateTime(5.1, 500)	~~~~~051A003A01F431↓.....
Measurement Loop			
Read Angle	Angle = ReadAngle(5.1)	~~~~~051D0000000013↓.....

4. CONFIGURATION WITH WYLER NETWORK AND WITH WYLER SW "DYNAM"

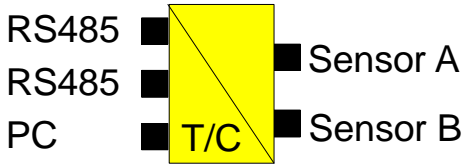
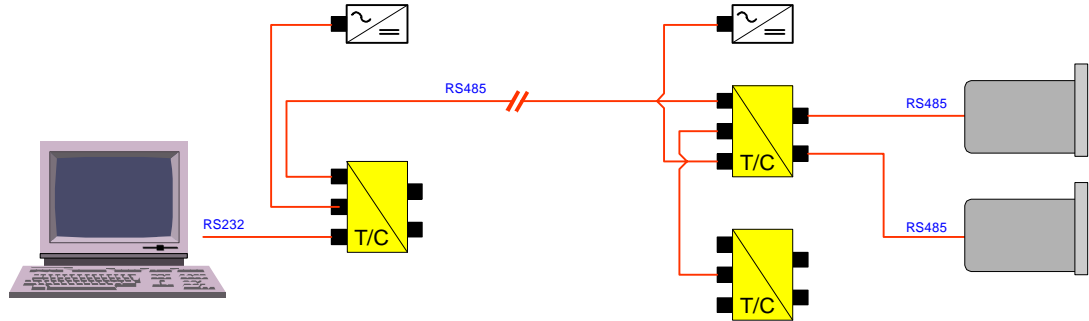

General:

The following specifications are valid when the data is computed by the WYLER SOFTWARE "DYNAM" (WIN16-API) in a bus system as seen above.

Specifications:

The maximum sampling rate depends on the possible baudrate (given by the performance of the computer), the number of sensors connected and the type of sensor (Type 2 or Type 3). The values below are meant to be typical values only)

Type 2

Processor Type PC	Maximum Baud rate	Maximum Sampling rate [1/sec]	Sampling Time e.g. 1 sensor connected [sec]	Sampling Time e.g. 5 sensors connected [sec]
486DX33 or higher	57600	30	0.033	0.166
486SX25	28800	15	0.066	0.333
386SX20	19200	10	0.100	0.500
286	9600	5	0.200	1.000

Type 3

Processor Type PC	Maximum Baud rate	Maximum Sampling rate [1/sec]	Sampling Time e.g. 1 sensor connected [sec]	Sampling Time e.g. 5 sensors connected [sec]
486DX33 or higher	57600	90	0.011	0.055
486SX25	28800	45	0.022	0.111
386SX20	19200	30	0.033	0.166
286	9600	15	0.066	0.333